

Tachogeneratoren

Vollwelle $\varnothing 11$ mm mit EURO-Flansch B10

Gehäuse $\varnothing 115$ mm

GTF7



Merkmale

- Leerlaufspannung 10...60 mV pro U/min
- Vollwelle $\varnothing 11$ mm
- EURO-Flansch B10
- Hohe Signalgüte über den gesamten Drehzahlbereich dank patentierter Longlife Technik
- Temperaturkompensation der Tachospannung serienmäßig
- Geringes Trägheitsmoment
- Keine Hilfsenergie erforderlich

Technische Daten - elektrisch

Reversiertoleranz	$\leq 0,1$ %
Linearitätstoleranz	$\leq 0,15$ %
Temperaturkoeffizient	$\pm 0,05$ %/K (Leerlauf)
Isolationsklasse	B
Kalibriertoleranz	± 5 %
Klimatische Prüfung	Feuchte Wärme, konstant (IEC 60068-2-3, Ca)
Ankerkreis-Zeitkonstante	< 4 μ s
Leerlaufspannung	10...60 mV pro U/min

GTF 7.08

Leistung	0,3 W (Drehzahl ≥ 5000 U/min)
----------	------------------------------------

GTF 7.16

Leistung	0,6 W (Drehzahl ≥ 5000 U/min)
----------	------------------------------------

Technische Daten - mechanisch

Baugröße (Flansch)	$\varnothing 115$ mm
Wellenart	$\varnothing 11$ mm Vollwelle
Flansch	EURO-Flansch B10
Schutzart DIN EN 60529	IP 55
Drehmoment	1,5 Ncm
Werkstoffe	Gehäuse: Edelstahl / Kunststoff Welle: Edelstahl
Betriebstemperatur	-30...+130 °C
Widerstandsfähigkeit	DIN EN 60068-2-6 Vibration 10 g, 10-2000 Hz DIN EN 60068-2-27 Schock 100 g, 6 ms

Anschluss	Schraubklemmenanschluss
-----------	-------------------------

GTF 7.08

Trägheitsmoment Rotor	0,4 kgcm ²
Masse ca.	0,9 kg

GTF 7.16

Trägheitsmoment Rotor	0,6 kgcm ²
Masse ca.	1,1 kg

Tachogeneratoren

Vollwelle ø11 mm mit EURO-Flansch B10
Gehäuse ø115 mm

GTF7

Bestellbezeichnung

GTF7.08L/4

Leerlaufspannung
10 10 mV pro U/min
20 20 mV pro U/min
30 30 mV pro U/min

GTF7.16L/4

Leerlaufspannung
40 40 mV pro U/min
60 60 mV pro U/min

Daten nach Typ

Typ	Leerlaufspannung U_0 [mV/U/min]	Min. erforderlicher Lastwiderstand in Abhängigkeit vom Drehzahlbereich [U/min]			Max. Betriebsdrehzahl n_{max} [U/min]	Anker-Widerstand R_A (20°C) [Ω]	Anker-Induktivität L_A [mH]
		0-3000	0-6000	0- n_{max}			
GTF7.08L/410	10	≥ 5	≥ 12	≥ 27	9000	60	20
GTF7.08L/420	20	≥ 20	≥ 48	≥ 108	9000	230	80
GTF7.08L/430	30	≥ 45	≥ 108	≥ 243	9000	550	180
GTF7.16L/440	40	≥ 40	≥ 96	≥ 216	9000	410	160
GTF7.16L/460	60	≥ 90	≥ 215	≥ 223	6100	760	360

Überlagerte Welligkeit (für $\tau_{RC} = 0,3$ ms): $\leq 0,6\%$ (Spitze-Spitze) $\leq 0,25\%$ (effektiv)

Ersatzschaltbild

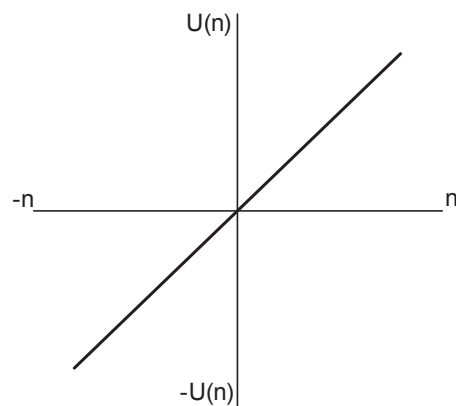
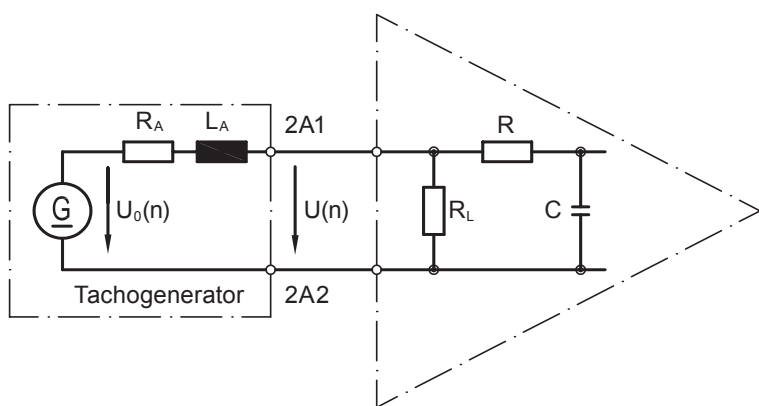

$$\tau_{RC} \approx R \cdot C \quad \tau_A \approx \frac{L_A}{R_L}$$

$$U(n) = U_0(n) \frac{R_L}{R_A + R_L} \approx U_0(n) \text{ für } R > R_L \gg R_A$$

Polarität bei positiver Drehrichtung: 2A1: + 2A2: - (VDE)

Tachogeneratoren

Vollwelle $\varnothing 11$ mm mit EURO-Flansch B10

Gehäuse $\varnothing 115$ mm

GTF7

Anschlussbelegung

Ansicht A - Anschlussklemmen

Polarität bei positiver Drehrichtung

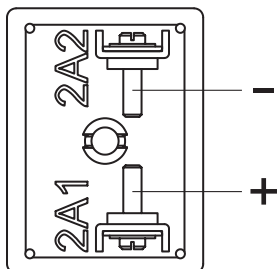

Zubehör

Kohlebürsten

Montagezubehör

K 35	Federscheiben-Kupplung für Vollwelle $\varnothing 6...12$ mm
K 50	Federscheiben-Kupplung für Vollwelle $\varnothing 11...16$ mm
K 60	Federscheiben-Kupplung für Vollwelle $\varnothing 11...22$ mm

Abmessungen

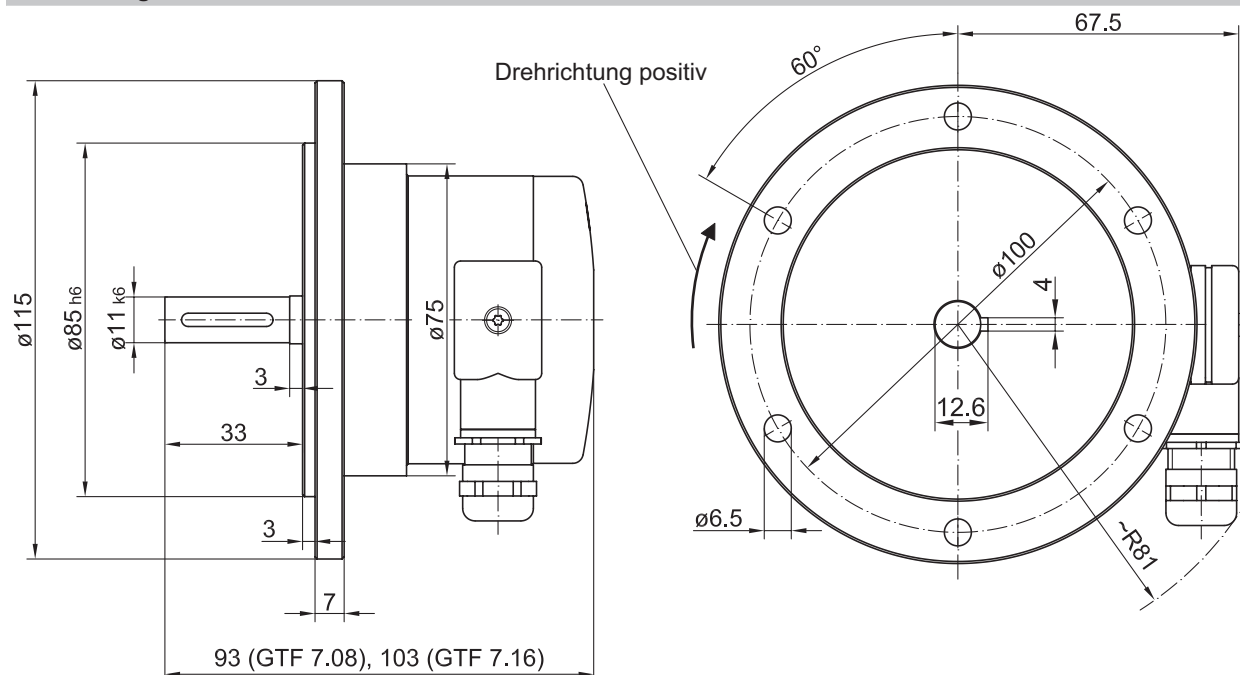

Tachogenerators

Solid shaft $\varnothing 11$ mm with EURO flange B10

Housing $\varnothing 115$ mm

GTF7



Features

- Open circuit voltage 10...60 mV per rpm
- Solid shaft $\varnothing 11$ mm
- EURO flange B10
- High signal quality due to patented LongLife technology
- Temperature compensation of tacho voltage as standard
- Low moment of inertia
- No auxiliary energy source required

Technical data - electrical ratings

Reversal tolerance	≤ 0.1 %
Linearity tolerance	≤ 0.15 %
Temperature coefficient	± 0.05 %/K (open-circuit)
Isolation class	B
Calibration tolerance	± 5 %
Climatic test	Humid heat, constant (IEC 60068-2-3, Ca)
Armature-circuit time-constant	< 4 μ s
Open-circuit voltage	10...60 mV per rpm

GTF 7.08

Performance	0.3 W (speed ≥ 5000 rpm)
-------------	-------------------------------

GTF 7.16

Performance	0.6 W (speed ≥ 5000 rpm)
-------------	-------------------------------

Technical data - mechanical design

Size (flange)	$\varnothing 115$ mm
Shaft type	$\varnothing 11$ mm solid shaft
Flange	EURO flange B10
Protection DIN EN 60529	IP 55
Torque	1.5 Ncm
Materials	Housing: stainless steel / plastic Shaft: stainless steel
Operating temperature	-30...+130 °C
Resistance	DIN EN 60068-2-6 Vibration 10 g, 10-2000 Hz DIN EN 60068-2-27 Shock 100 g, 6 ms
Connection	Screw terminal connector

GTF 7.08

Rotor moment of inertia	0.4 kgcm ²
Weight approx.	0.9 kg

GTF 7.16

Rotor moment of inertia	0.6 kgcm ²
Weight approx.	1.1 kg

Tachogenerators

Solid shaft $\varnothing 11$ mm with EURO flange B10
Housing $\varnothing 115$ mm

GTF7

Part number

GTF7.08L/4

Open-circuit voltage
10 10 mV per rpm
20 20 mV per rpm
30 30 mV per rpm

GTF7.16L/4

Open-circuit voltage
40 40 mV per rpm
60 60 mV per rpm

Data according to type

Type	Open-circuit voltage	Minimum load required depending on speed range [rpm]			Maximum operating speed	Armature resistance	Armature inductance
		0-3000	0-6000	0- n_{\max}			
	U_0 [mV/rpm]	R_L [k Ω]	R_L [k Ω]	R_L [k Ω]	n_{\max} [rpm]	R_A (20°C) [Ω]	L_A [mH]
GTF7.08L/410	10	≥ 5	≥ 12	≥ 27	9000	60	20
GTF7.08L/420	20	≥ 20	≥ 48	≥ 108	9000	230	80
GTF7.08L/430	30	≥ 45	≥ 108	≥ 243	9000	550	180
GTF7.16L/440	40	≥ 40	≥ 96	≥ 216	9000	410	160
GTF7.16L/460	60	≥ 90	≥ 215	≥ 223	6100	760	360

Superimposed ripple (for $\tau_{RC} = 0.3$ ms): $\leq 0.6\%$ (peak-peak) $\leq 0.25\%$ (rms)

Replacement switching diagram

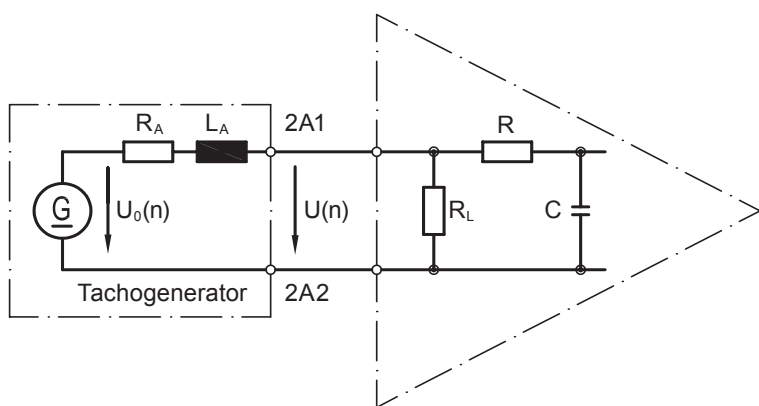

$$\tau_{RC} \approx R \cdot C \quad \tau_A \approx \frac{L_A}{R_L}$$

Polarity for positive rotating direction: 2A1: + 2A2: - (VDE)

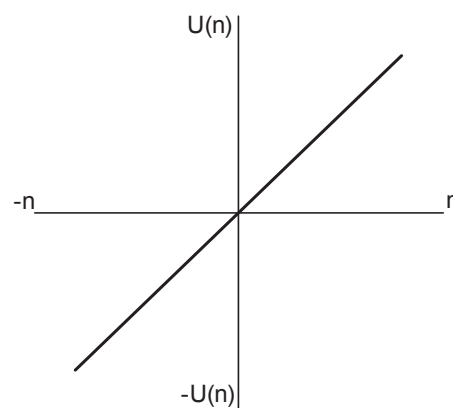

$$U(n) = U_0(n) \frac{R_L}{R_A + R_L} \approx U_0(n) \text{ for } R > R_L \gg R_A$$

Tachogenerators

Solid shaft $\varnothing 11$ mm with EURO flange B10

Housing $\varnothing 115$ mm

GTF7

Terminal assignment

View A - Connecting terminal

Polarity for positive direction of rotation

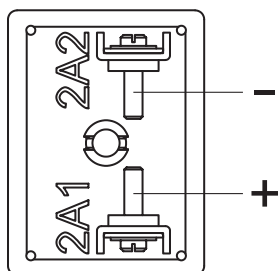

Accessories

Carbon brushes

Mounting accessories

K 35	Spring disk coupling for solid shaft $\varnothing 6...12$ mm
K 50	Spring disk coupling for solid shaft $\varnothing 11...16$ mm
K 60	Spring disk coupling for solid shaft $\varnothing 11...22$ mm

Dimensions

